

Specifications	
Description	Lifts and tilts to aid unloading of small containers
Materials	304 grade stainless steel
Bin Types	Drums, Barrels and similar containers
Safe working load	350kg
Tip angle	Up to 125°
Power supply for recharging	240V single phase, 50Hz, 13 amp
Battery, motor and control voltage	12V DC
Operating environment temperature	-10°C to 40°C
Controls	Hold to run push buttons
Drive type	Battery powered hydraulics
Mass	280kg

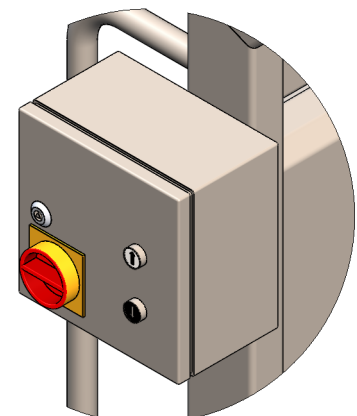
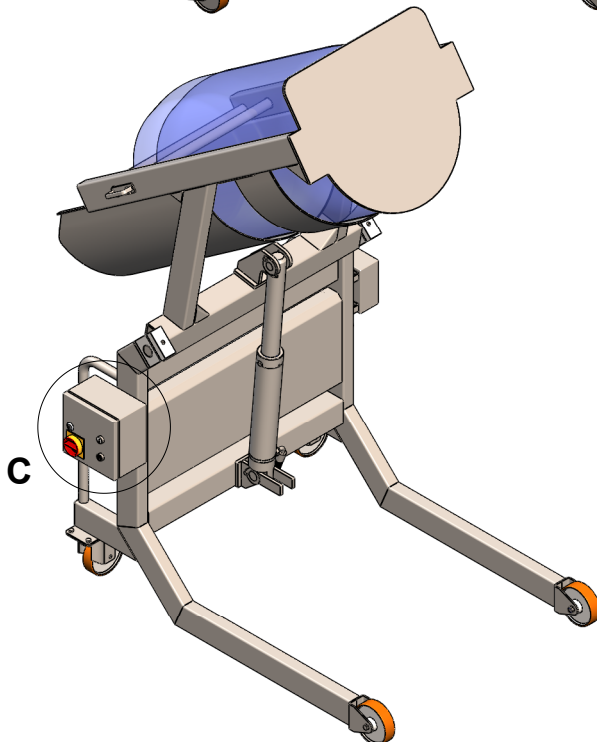
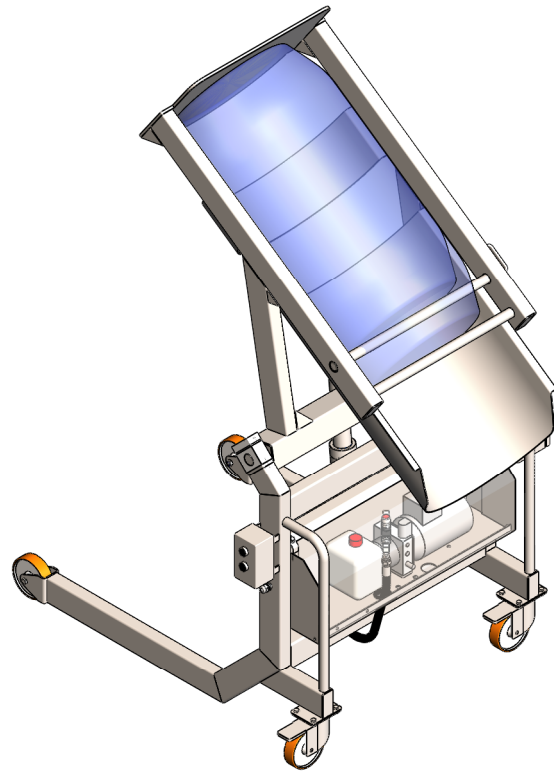
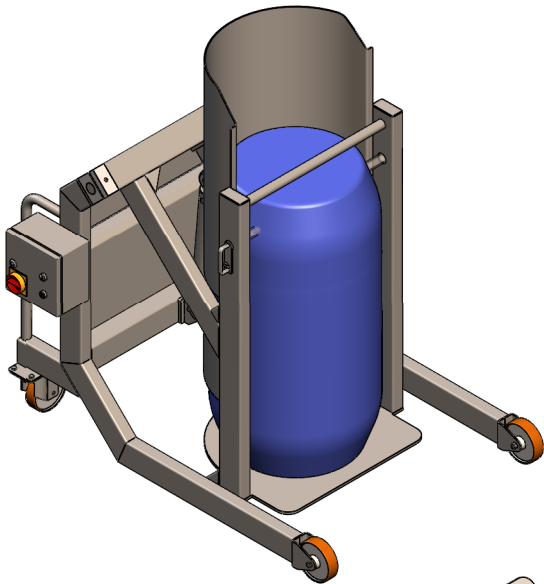
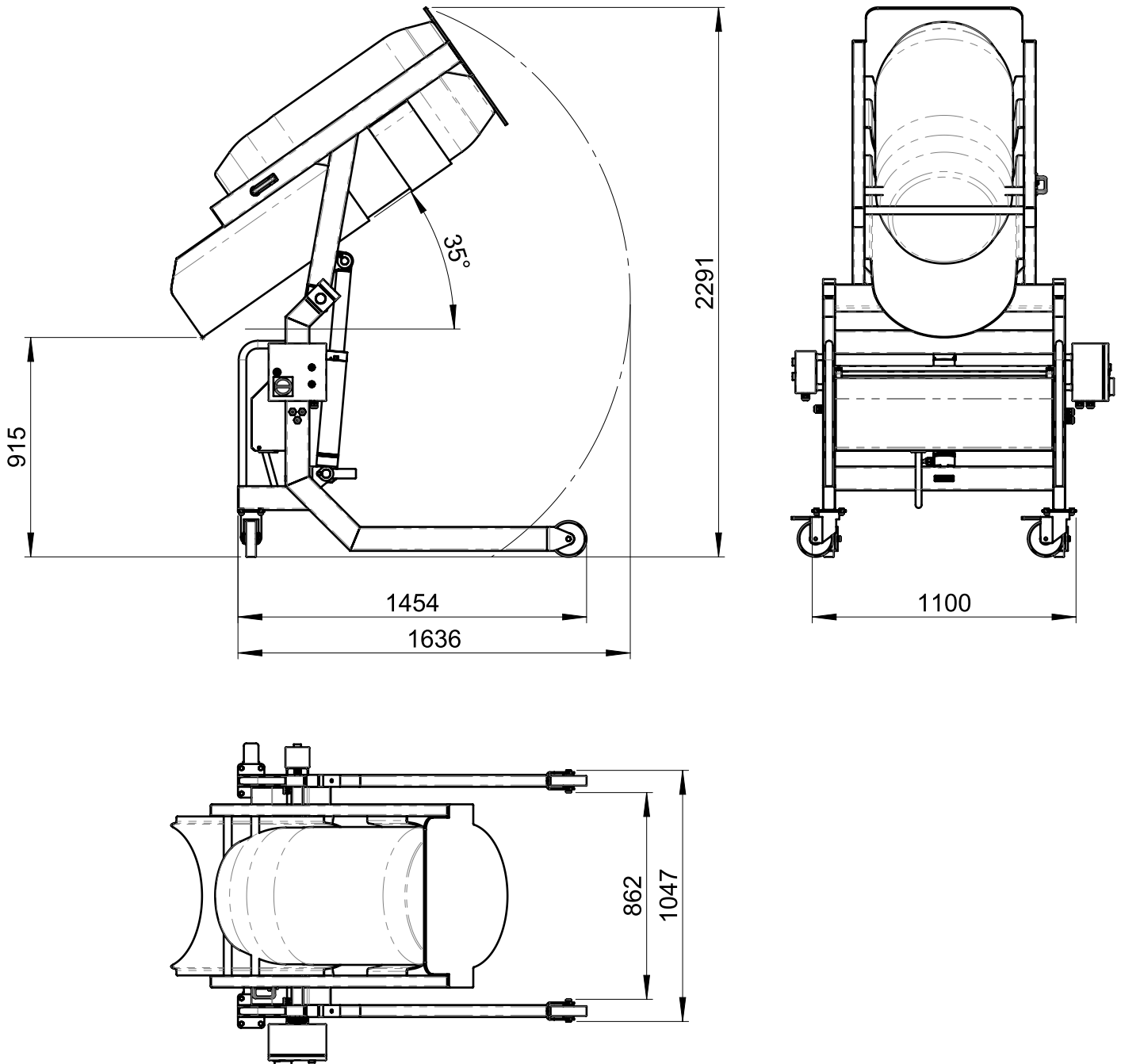

DETAIL C

**Information required**

Container	Overall dimensions, weight, diameter of opening
Product type	Weight of product in the container. Name and characteristics of product
Charger type	Either non-IP rated (to be used in a dry area) or IP 65



**SYSPAL LTD Cockshutt Lane, Broseley, Telford, Shropshire, TF12 5JA, England**

t: +44 (0) 1952 883188 f: +44 (0) 1952 884093 e: <mailto:sales@sypal.com>

[www.sypal.com](http://www.sypal.com)

Notes :