

Specifications	
Description	Transfers 200 litre eurobins to and from Syspal standard racking
Bin type	Standard 200 and 300 litre eurobins (DIN97979)
Safe working load	250kg
Lifting speed	4m/min or 67mm/sec
Power supply for recharging	240V single phase, 50Hz, 13 amp
Battery, motor and control voltage	12V DC
Battery capacity	85Ah
Operating environment temperature	-10°C to 40°C
Materials	304 grade stainless steel
Controls	Hold to run push buttons
Drive type	Battery powered hydraulics
Mass	400kg

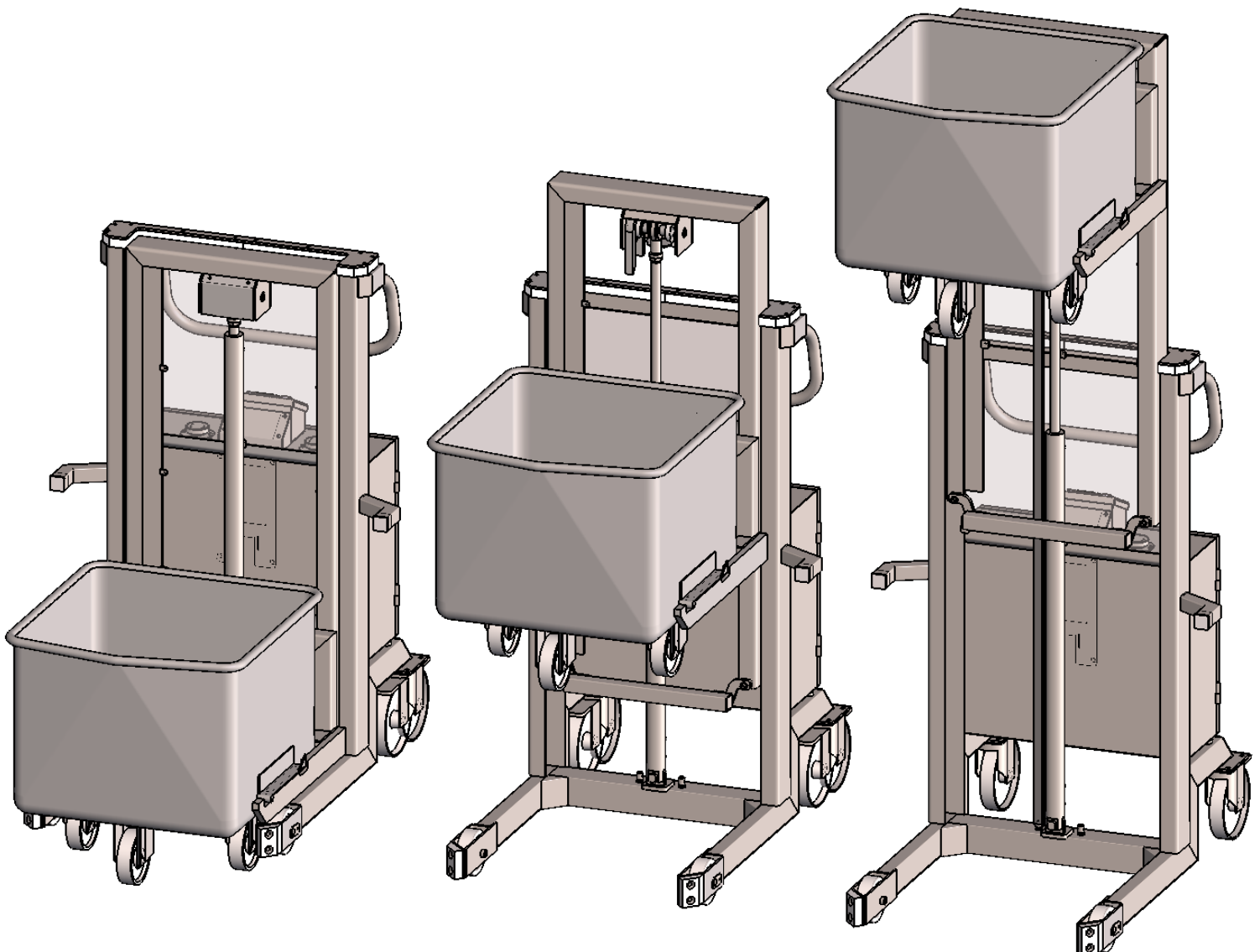

**Information required**

Headroom	Minimum headroom available
Access	Doorway width
Temperature	Ambient temperature of the room
Bin lids	The type of bin lids in use (if any) Note this can affect the headroom needed

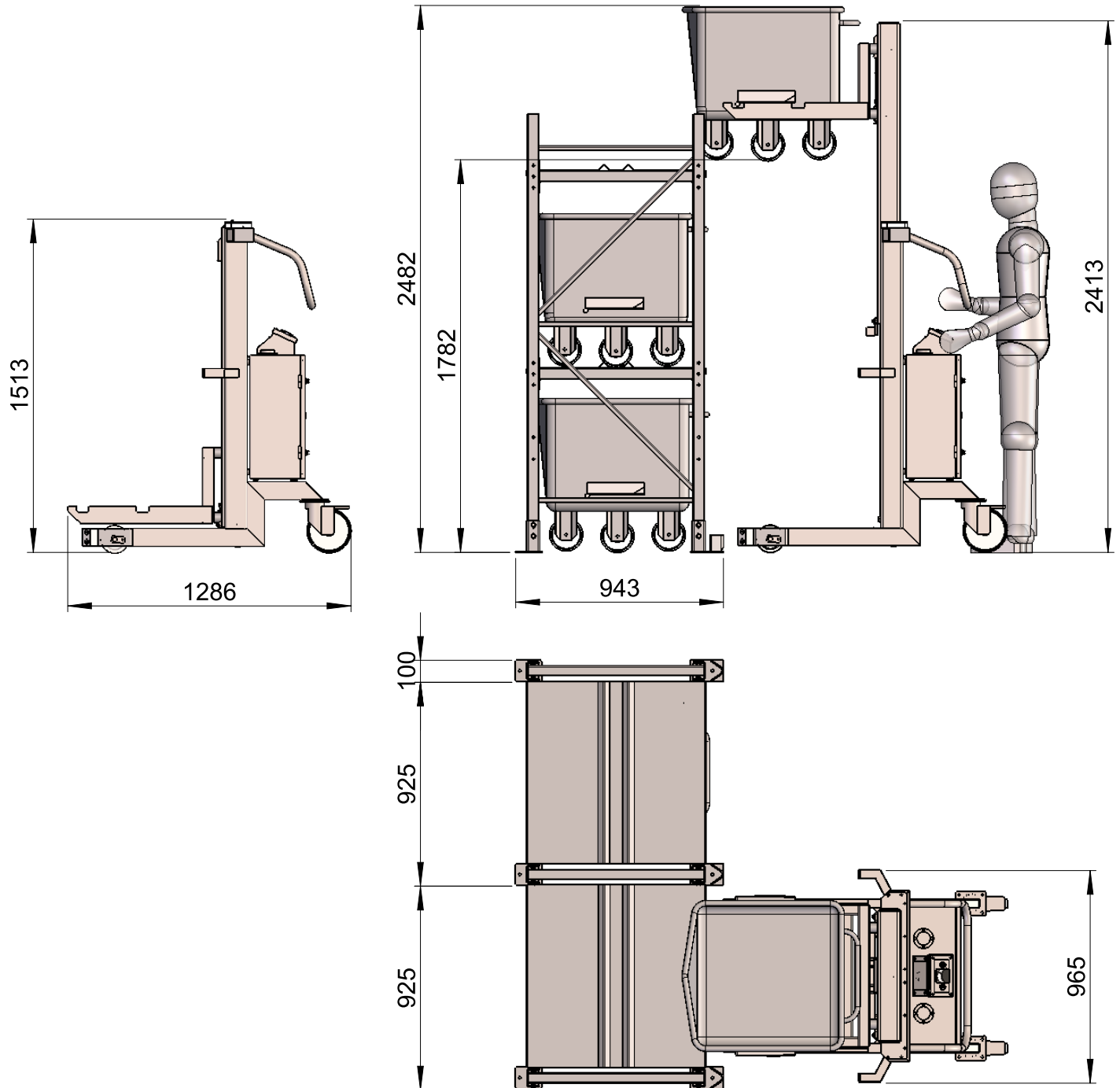

**SYSPAL LTD Cockshutt Lane, Broseley, Telford, Shropshire, TF12 5JA, England**

t: +44 (0) 1952 883188 f: +44 (0) 1952 884093 e: <mailto:sales@sypal.com>

[www.sypal.com](http://www.sypal.com)