

Specifications	
Description	Free standing unit eliminates the need for floor pits and ramps.
Materials	304 grade stainless steel
Bin Type	200 and 300 litre eurobins (DIN 9797) + chuted variations
Option	120L With additional adaptor brackets
Capacity	350kg
Power supply	Universal power supply: 85 to 264 V AC single phase. 49 to 61Hz, 13 amp
Operating environment temperature	-10°C to 40°C
Indicator type	Mettler Toledo digital indicator - See comparison table for options available
Controls	Manual lever linkage with gas spring assist

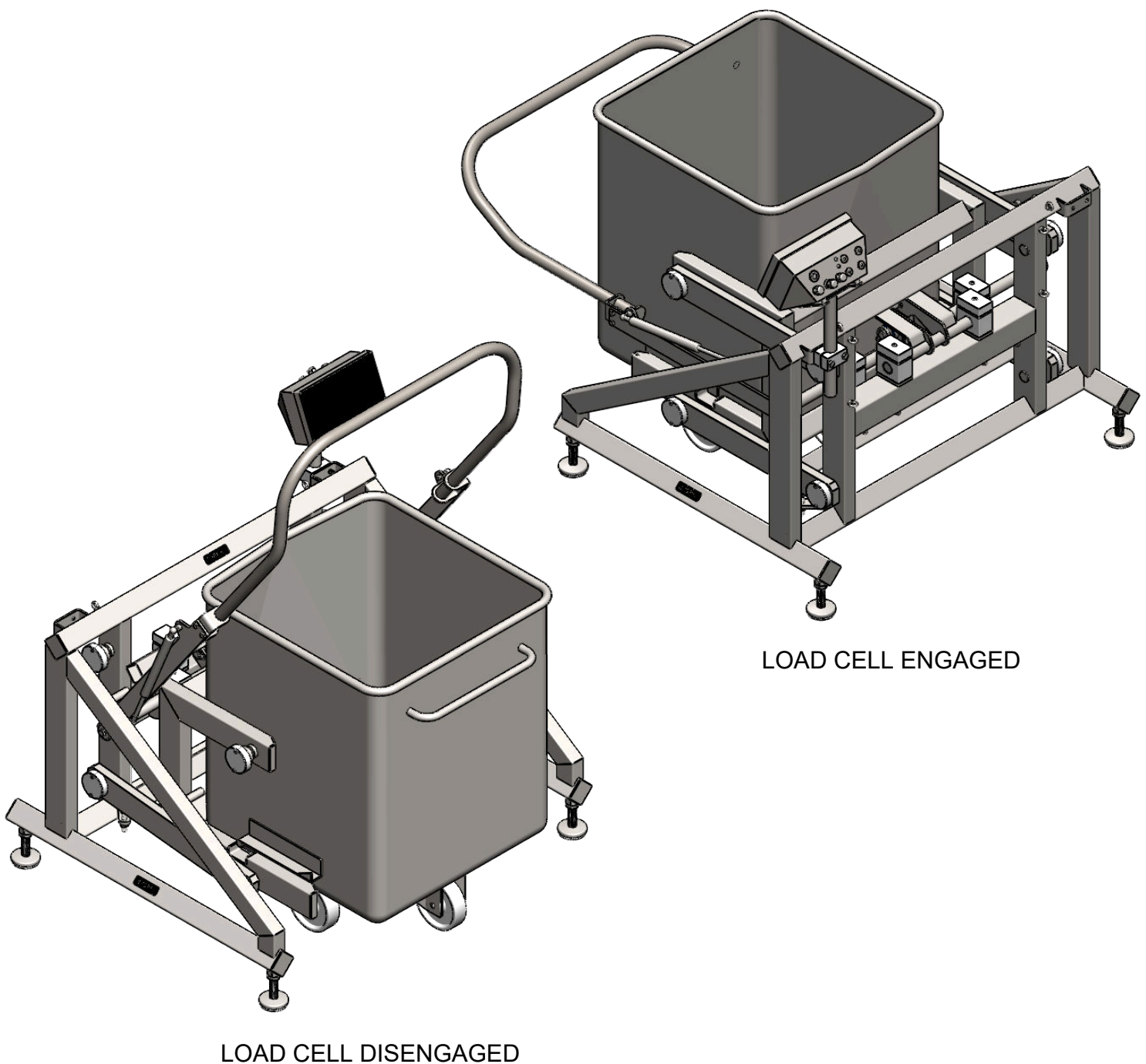

METTLER TOLEDO  
INDICATOR

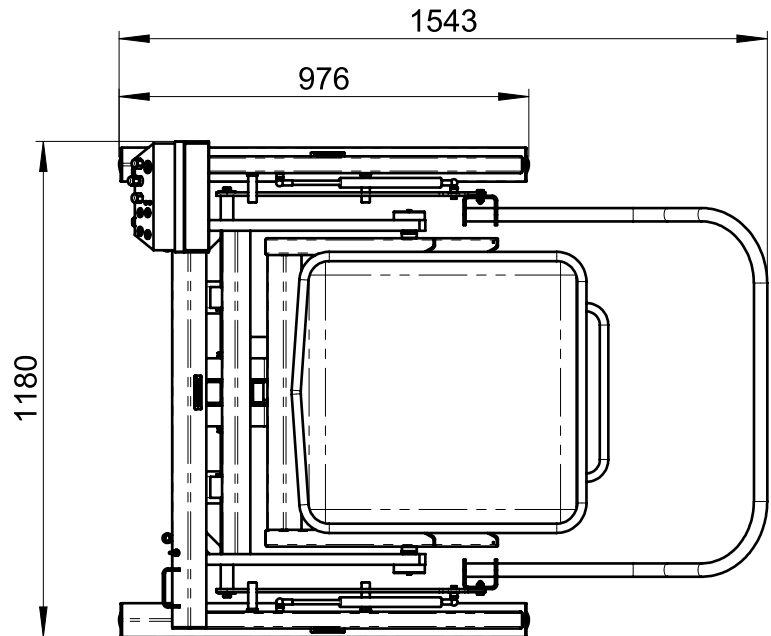
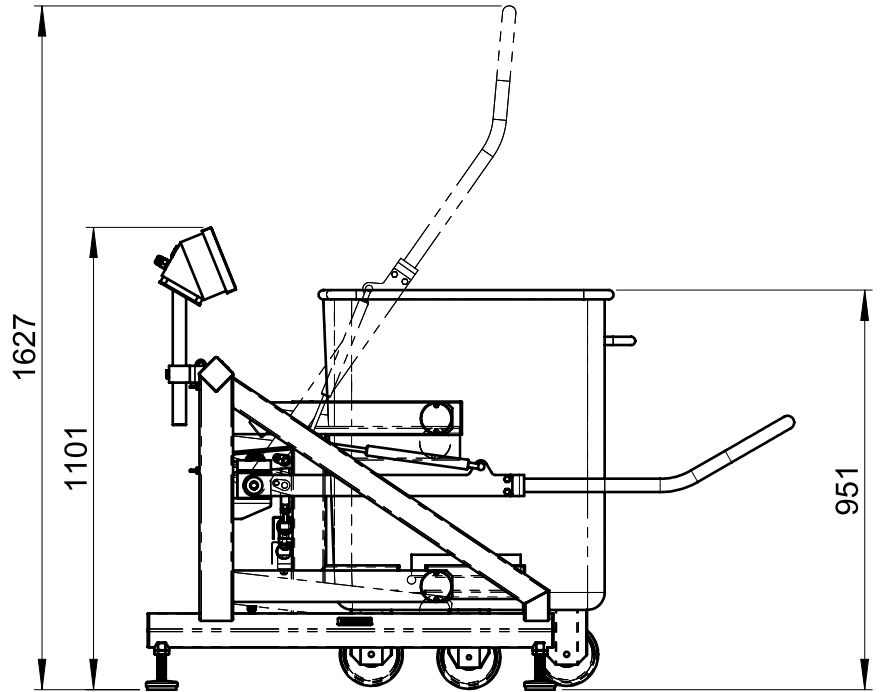
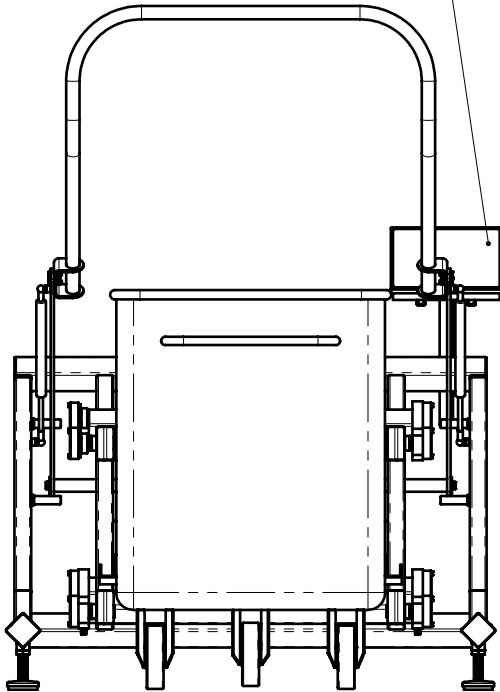

**SYSPAL LTD** Cockshutt Lane, Broseley, Telford, Shropshire, TF12 5JA, England

t: +44 (0) 1952 883188 f: +44 (0) 1952 884093 e: [sales@syspal.com](mailto:sales@syspal.com)

[www.syspal.com](http://www.syspal.com)

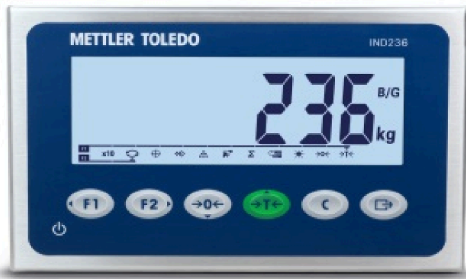
**COMPARISON TABLE FOR DISPLAY HEADS**

MODEL	IND236	IND570
CONSTRUCTION	STAINLESS STEEL	STAINLESS STEEL
HOUSING	WALL MOUNT (IP66/IP67)	WALL MOUNT / PANEL MOUNT (IP69K)
DIMENSIONS	220 X 150 X 93.3	265.0 X 148.4 X 162.9
DISPLAY	40MM HEIGHT WITH WHITE BACKLIGHT	25MM OLED DISPLAY HI RESOLUTION
POWER	85VAC – 264VAC 50 – 60HZ	85VAC – 264VAC 49-61HZ 750MA
SCALE INTERFACE	1 ANALOG – UPTO 4 350OHM LOADCELLS	1 ANALOG – UPTO 12 350OHM LAODCELLS OR 1 IDNET SCALE INTERFACE OR 1 SICSPRO SCALE INTERFACE
SCALE RESOLUTION	UPTO 30,000 SCALE DIVISIONS CAN BE CONFIGURED	UPTO 100,000 DISPLAYED INCREMENTS CAN BE CONFIGURED.
EXCITATION VOLT.	5VDC	10VDC
UNITS	G, KG, LB, OZ	KG, LB, T, METRIC T, G, DWT, LB-OZ, OZT AND CUSTOM UNITS.
KEYPAD	ZERO, TARE, CLEAR, ON/OFF, PRINT, F1 & F2	CLEAR, TARE, PRINT, ZERO KEYS. FULL APHANUMERIC KEYPAD. 15 CUSTOMISABLE SOFTKEYS. SUPPORTS PRESET TARE VALUES.
COMMUNICATION	COM1 RS232 AS STANDARD. COM2 RS232/RS422/RS485 CONFIGURABLE WITH DIGITAL IO AS OPTION.	STANDARD COM1 RS232/422/485 CONFIG. USB HOST. AS STANDARD. OPTIONAL ETHERNET IF. SUPPORTS UPTO 15 INPUTS AND 20 OUTPUTS.
FIELDBUS CONNECTIVIY	NONE	ETHERNETIP, ANALOG OUTPUT, PROFIBUS DP, CONTROLNET, DEVICENET, MODBUS TCP
INTEGRATED APPLICATIONS	BASIC WEIGHING OVER / UNDER CHECKWEIGHING WITH 10 RECORDS.	BASIC WEIGHING WITH PRESET TARE AND ALIBI MEMORY. TRANACTION COUNTER. ALIBI MEMORY AS STANDARD. 2 SPEED SINGLE MATERIAL FILLING OF 200 TARGETS. OVER UNDER CHECKWEIGHING. UPTO 10 PROGRAMMABLE PRINT TEMPLATES. SUPPORTS UPTO 30 ID PROMPTING PROGRAMMABLE SEQ USB FILE TRANSFER.

**Notes :**