

Specifications	
Description	Lifts and tips product onto an acceptance table or hopper
Materials	304 grade stainless steel
Bin Type	Containers such as, Dolavs, pallet boxes palletainers
Safe working load	1000kg
Standard tip angles	110°
Battery version - charger power supply	240V single phase, 50Hz, 13 amp
Battery version - motor and control voltage	12V DC
Battery version - IP rating	IP55 controls with ventilated battery enclosure
Mains supply version - supply	415 volt (3-phase, neutral and earth, 50Hz, 16 amp)
Mains supply version - control voltage	24V AC
Mains supply version - IP rating	IP55 minimum
Controls	Hold to run push buttons on both sides

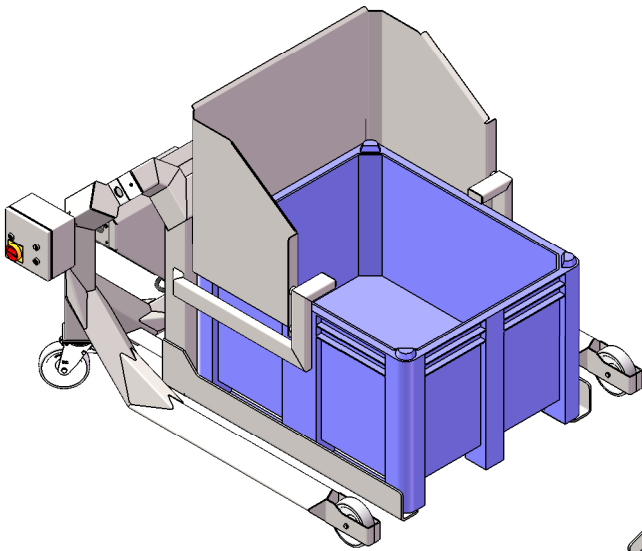

Mobile base version

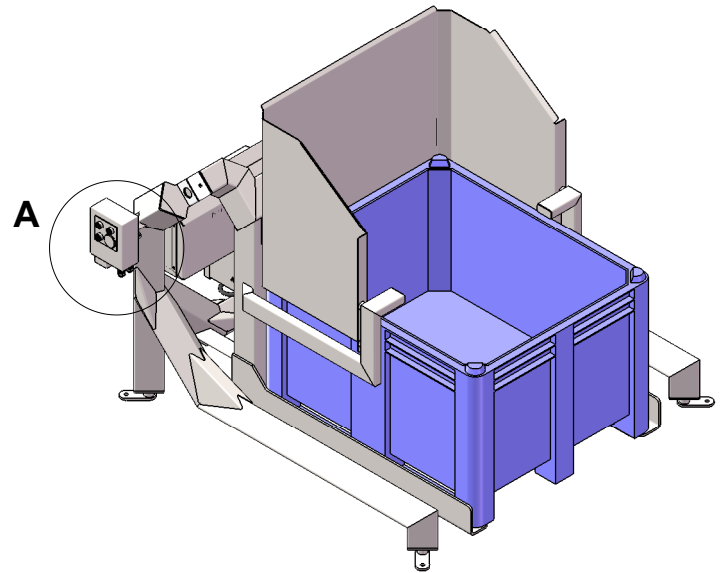

Bolted base version

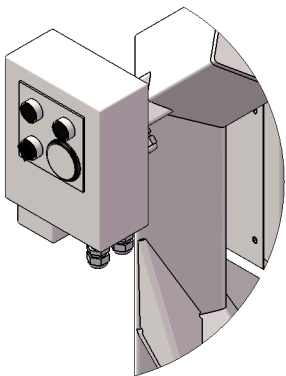
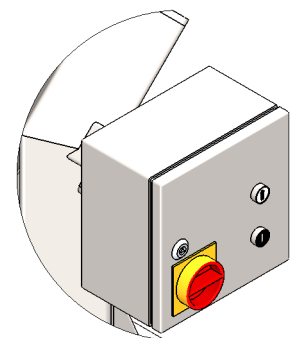
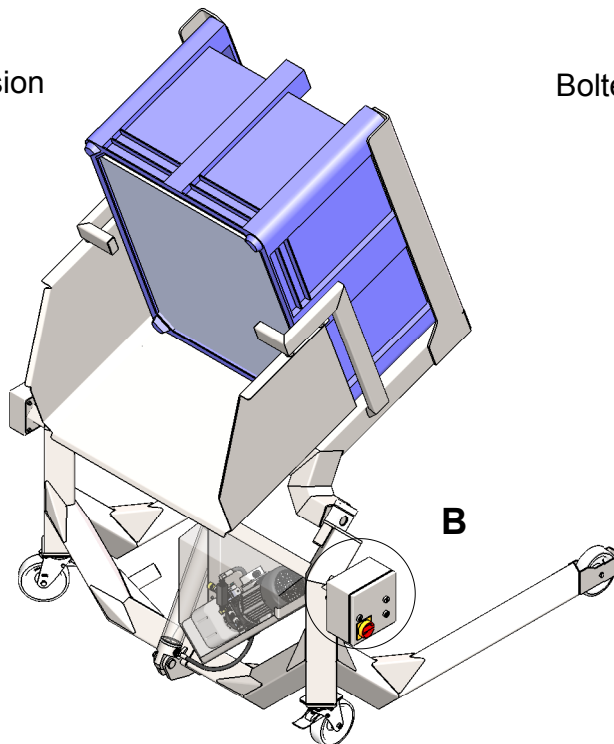
DETAIL A
3 phase supply versionDETAIL B
12V battery version

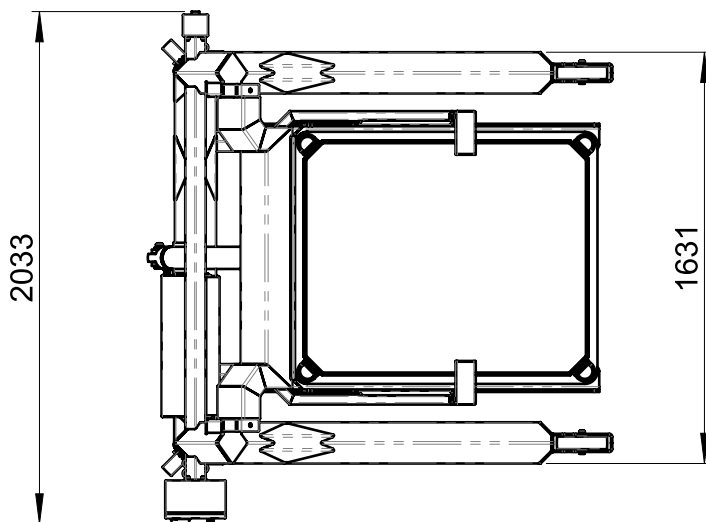
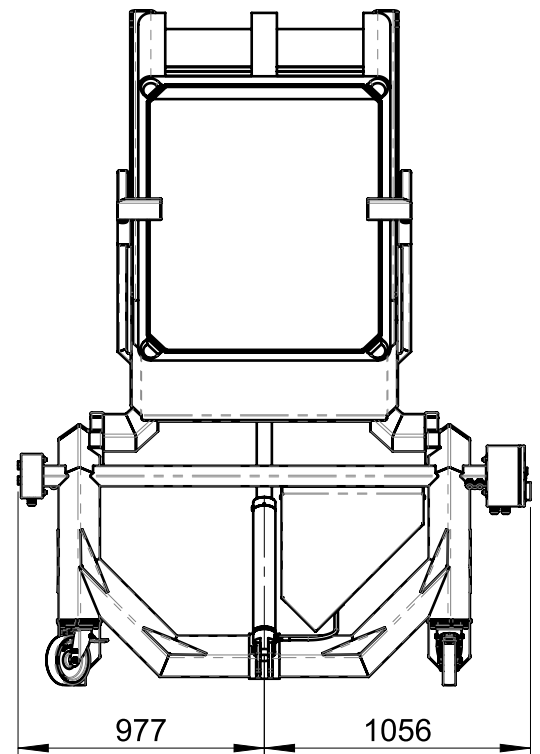
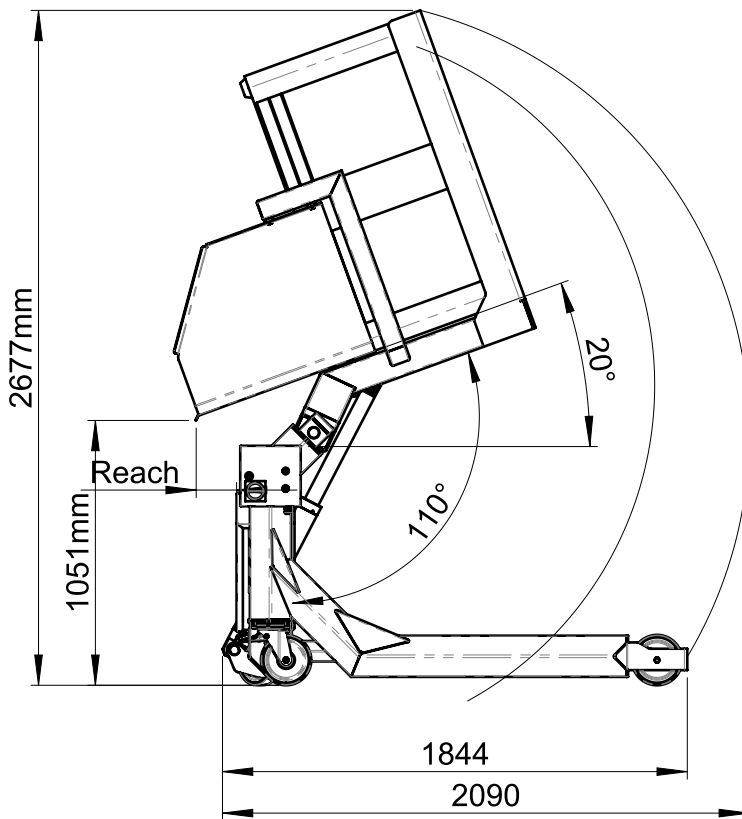

Information required

Product type	Name and information of the product
Tip height	Height and angle of chute required
Reach	The horizontal distance needed between tipper and receiving hopper / table



SYSPAL LTD Cockshutt Lane, Broseley, Telford, Shropshire, TF12 5JA, England

t: +44 (0) 1952 883188 f: +44 (0) 1952 884093 e: <mailto:sales@sypal.com>

www.sypal.com

Notes :