

| Specifications | |
|-----------------------------------|---|
| Description | Lifts and tips product from mixing bowls into buggies |
| Materials | 304 grade stainless steel |
| Bin Type | Most types of mixing bowl |
| Safe working load | 1000kg |
| Tip angle | 125° (35° from horizontal) |
| Power supply | 415 volt, 3ph, 50Hz |
| Control voltage | 24V AC |
| Operating environment temperature | -10°C to 40°C |
| Controls | Hold to run push buttons |
| Drive type | Three phase hydraulic power pack |
| IP rating | IP65 minimum |

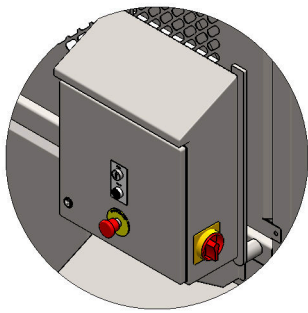

DETAIL A

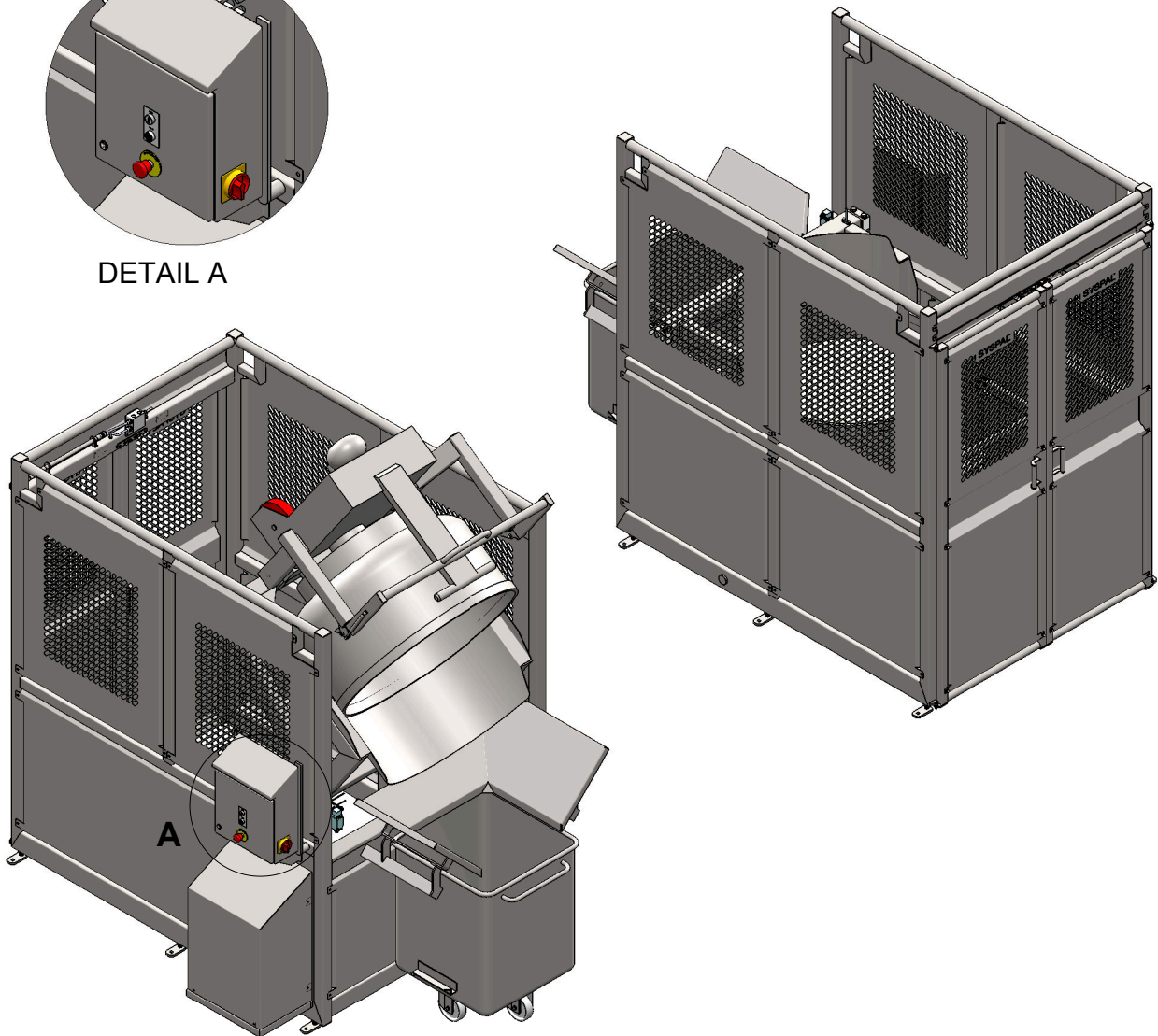

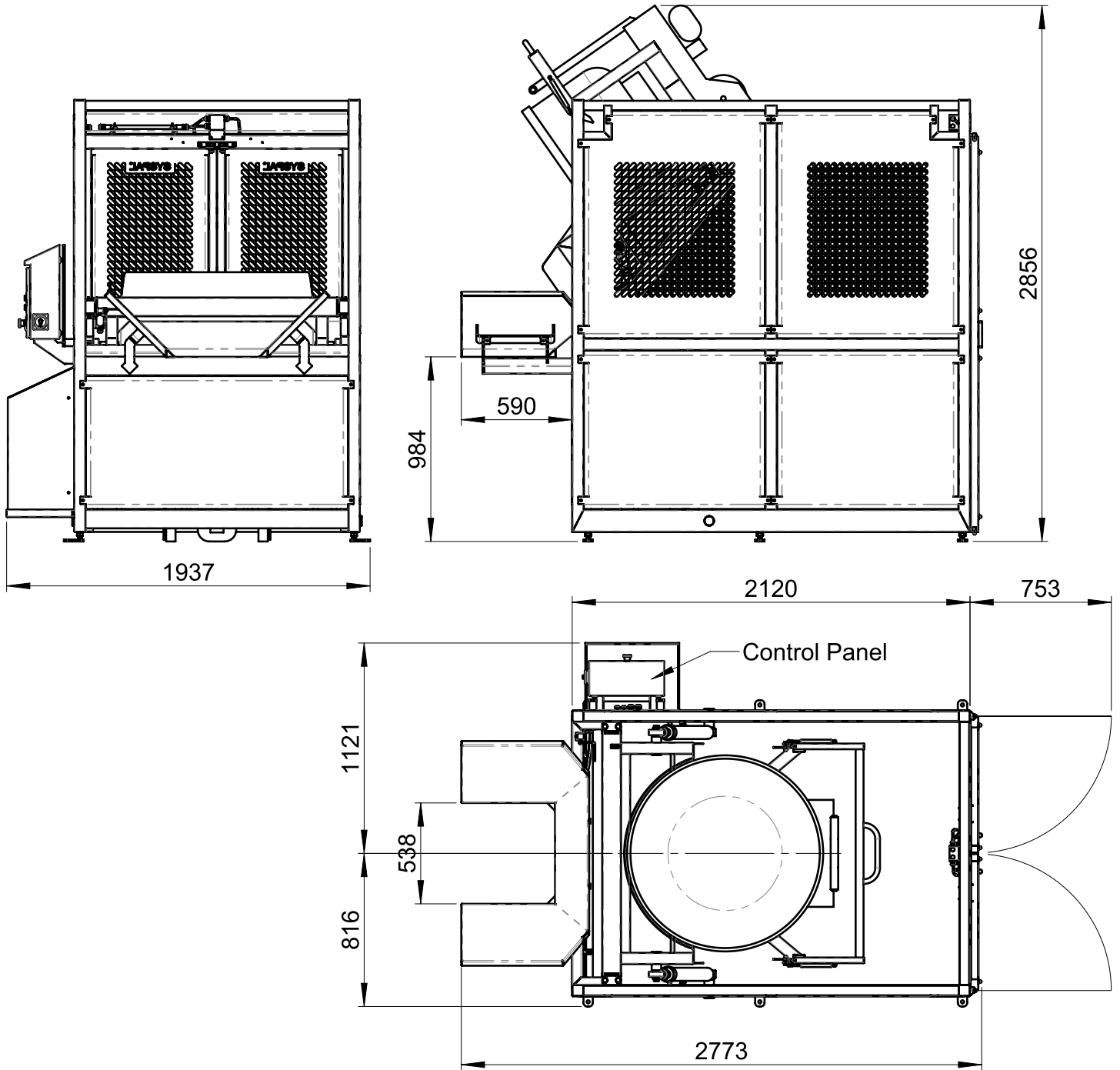

| Information required | |
|-------------------------|---|
| Container | Overall dimensions and type |
| Access for installation | Dimensions of corridors and doorways |
| Product type | Name and characteristics of the product |

SYSPAL LTD Cockshutt Lane, Broseley, Telford, Shropshire, TF12 5JA, England

t: +44 (0) 1952 883188 f: +44 (0) 1952 884093 e: <mailto:sales@sypal.com>

www.sypal.com

Notes :